

**Switchgear for
driver's desks**
Toggle switches
F, L, P Series
Timetable holder BFH

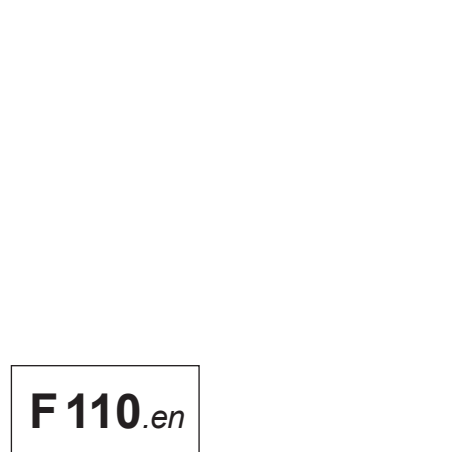
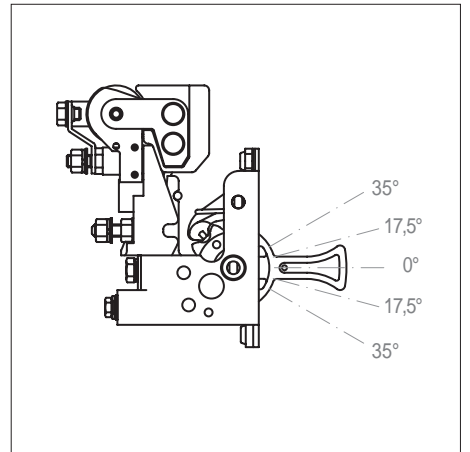
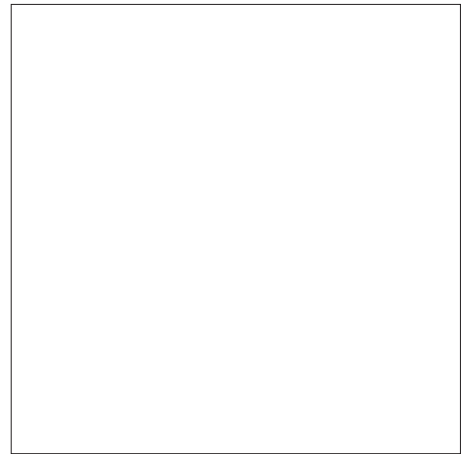
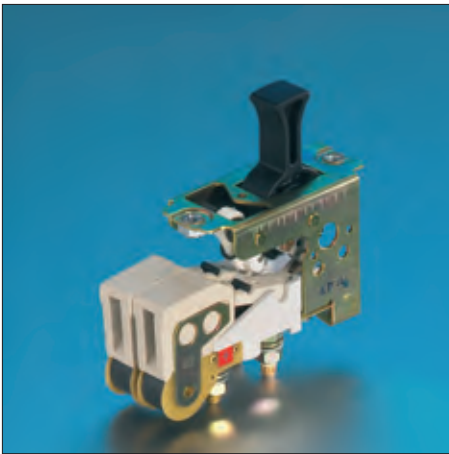

Toggle switch assemblies for driver's desks

Schaltbau toggle switch assemblies F, L, and P Series are suitable for the rough operating environment. Sturdy construction and a long design life make them especially useful for railway applications in mainline and commuter rail service as well as for certain industrial applications.

BFH Series timetable holders are mounted in many driver's desks of locomotives and multiple units for fixing timetables and other printed media.

Features

- Compact and rugged design
- Great variety of variants and combinations
- In compliance with railway standard IEC 60077

Applications

- Driver's desks of rolling stock on mainline and commuter rail service
- Switchgear cabinets



Specifications

Toggle switch assemblies	Series F	Series L	Series P
Switch positions			
3-position contact assembly	2 x 30°	2 x 35°	2 x 35°
5-position contact assembly	4 x 15°	4 x 17.5°	4 x 17.5°
Switching elements			
Snap-action switch S800 / S826	• 3-position contact assembly	---	•
Snap-action switch S870	• 5-position contact assembly	---	---
Cam-operated S005 / S007 / S008	---	•	---
Number of switching elements	1 ... 2	1 ... 4	1 ... 4
Vibration resistance (IEC 61373, IEC 60068)	5 ... 20 Hz: 0.0193 g/Hz 20 ... 150 Hz: 7.9 m/sec ²	5 ... 20 Hz: 0.0193 g/Hz 20 ... 150 Hz: 7.9 m/sec ²	5 ... 20 Hz: 0.0193 g/Hz 20 ... 150 Hz: 7.9 m/sec ²
Shock resistance (IEC 61373, IEC 60068)	5 g / 22 msec, half sinus	5 g / 22 msec, half sinus	5 g / 22 msec, half sinus
Mechanical endurance	> 300,000 operations	> 100,000 operations	> 300,000 operations
Ambient temperature range T _a	-20°C ... +70°C	-20°C ... +70°C	-20°C ... +70°C
Weight			
with 1 switching element	170 g max.	230 g max.	200 g max.
with 2 switching elements	190 g max.	350 g max.	250 g max.
with 3 switching elements	---	400 g max.	300 g max.
with 4 switching elements	---	600 g max.	360 g max.

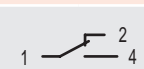

Schaltbau toggle switch assemblies are available in many variants and combinations. The following table shows the

electrical specifications of the switching elements with which the toggle switch assemblies can be equipped.

Switching elements	S800	S826	S870	S005	S007	S008
Rated insulation voltage U _i	400 V	400 V	250 V	400 V	400 V	400 V
Pollution degree	3	3	3	3	3	3
Rated impulse withstand voltage U _{imp}	4 kV	4 kV	4 kV			
Overvoltage category	III	III				
Conv. thermal current I _{th} at T _a = 85°C	10 A	10 A	10 A	15 A	25 A / 60 A	25 A / 60 A
Kind of switch	Snap-action switch			Cam-operated switching element		
Features	<ul style="list-style-type: none"> • Positive opening operation • Large contact bridge 	<ul style="list-style-type: none"> • Positive opening operation • Wiping contacts • Form Z SPDT-DB, galvanically isolated • Permanent-magnetic blowout 	<ul style="list-style-type: none"> • Positive opening operation • Wiping contacts • High resistance to shock and vibration 	<ul style="list-style-type: none"> • High current-carrying capacity up to 60 A max. • Large contacts, rugged design, long life • Permanent-magnetic blowout 		
Circuit diagram						
Catalogue	D20.en	D26.en	D70.en	D30.en		



Ordering code F, L, P Series

Example: **P-2S 6/6 S800A SH**

Series

F	Toggle switch assembly, F Series
L	Toggle switch assembly, L Series
P	Toggle switch assembly, P Series

Blocked position

3-position contact assemblies (F, L, P Series)

None	Blocked position, see tables: contact positions on pages 4 and 6
------	---

5-position contact assemblies (L, P Series)

None	No blocked position
1	Blocked downwards (-17.5° / -35°)
2	No intermediate ±17.5°, only ±35°
3	Blocked upwards (+17.5° / +35°)
4	Blocked downwards, only -35°

Switch function

F Series

SOU / SO / SU TOU / TO / TU TOSU / TUSO SSOU / TSOU	} Table: switch function code, see page 4
--	--

L, P Series

S / 2S / ST / TS T / V / VD / DV	} Table: switch function code, see page 6
-------------------------------------	--

Number of switching elements / contact positions

F Series

3-position contact assemblies

1 ... 22	} Table: contact positions, see page 4
5-position contact	
23 ... 52	

L, P Series

3-position contact assemblies

1 ... 10	} Table: contact positions, see page 6
5-position contact	
5 ... 34	

Switching elements

F Series

OE	S800 e, screw-type terminals
OE20	S800 e24, flat quick-connect terminals
E	S826 e, screw-type terminals
E20	S826 e24, flat quick-connect terminals
W	S870 W1A1r, screw-type terminals
W20	S870 W1D1r, flat quick-connect terminals

L Series

S5	S005 a
S6	S007 c
S7	S007 a
P5	S008 P5
P6	S008 P6

P Series

S800 a	Screw-type terminals
S800 a24	Flat quick-connect terminals
S800 a30	Screw with spring washer
S826 a	Screw-type terminals
S826 a24	Flat quick-connect terminals
S826 a/L	Screw-type terminals, blowout
S826 a10	Screw-type terminals, gold contacts
S826 a10/24	Flat quick-connect terminals, gold contacts

Special features

F Series

FL	Mounting with studs, thruhole Ø 5.5 mm
V	Lock
VL	Lock, extended

L, P Series

SE	Angle for earthing
SO	Mounting with studs, thruhole Ø 6.3 mm

Handles (F, L, P Series)

SH	Special handle, black
SHK	Ball handle, black
SHG	T-handle, black
SHL	Cylinder handle, long, black
SHM	Cylinder handle, short, black

Annotations:

Blocked position:

The upward and downward movement of the handle can be blocked mechanically.

Switch function:

Special variants with maintained or momentary contact function are available, see »Special Variants« below.

Number of switching elements / contact positions:

The maximum number of switching elements is four. Each switching element is represented by the index number of its contact position within the working range of the toggle switch assembly. So contact position »0« means there is no switching element.

Whenever one or two switching elements are used, they are arranged in order of ascending index numbers of their contact positions, e.g. L-T 7/9 P5, P-S 0/3 S826A24.

In assemblies using 3 or 4 switching elements the sequence is determined by the respective technical requirements: i.e. you order L-S 7/9/23/24 S5, we deliver L-S 7/23/24/9 S5.

Switching elements:

The standard toggle switch assembly comes with switching elements of the same type. If different types of switching elements are required, they should be named individually (separated by »/«) together with the preceding index number of their contact position. Example: L-TS 5S5/5P6/5P6

Special features:

Various handle design and mounting options are available - see also page 8.

Stock items

Only stock items are presented in this catalogue which can be supplied in short delivery time.

Special variant

If you need a special variant, do not hesitate to contact us. Maybe the type of toggle switch assembly you are looking for is among our many **special designs**. If not, we can also supply **customized designs**. In this case, however, minimum order quantities apply.

Note: Customized designs may have specifications that differ from those presented on page 2.

Switching elements

Series F

Series F toggle switch assemblies are available with S800, S826 or S870 Series snap-action switches. The switches feature positive opening operation that guarantees the failsafe opening of the NC contact even if it has become welded in a short-circuit situation.

Note: Use and order S840 Series snap-action switches only as spare parts!

Switching elements				
Snap-action switch	Code	Terminals	Contact positions	Catalogue
S800 e	OE	Screw-type	3-position assembly	D20
S800 e24	OE20	Quick-connect		
S826 e	E	Screw-type	3-position assembly	D26
S826 e24	E20	Quick-connect		
S870 W1A1r	W	Screw-type	3-position assembly	D70
S870 W1D1r	W20	Quick-connect	5-position assembly	

Snap-action switch	S870 / S840	S800 / S826
Circuit diagram		

Switching elements (Use and order only as spare part!)				
Snap-action switch	Code	Terminals	Contact positions	Catalogue
S840 r	R	Screw-type	5-position assembly	---
S840 r20	R20	Quick-connect		

Dimension diagrams

Series F

- **F Series** equipped with S870 snap-action switches featuring screw-type terminals with thread M4 (standard)

- **F Series** equipped with S800 / S826 snap-action switches featuring thruholes for mounting with studs (special design FL)

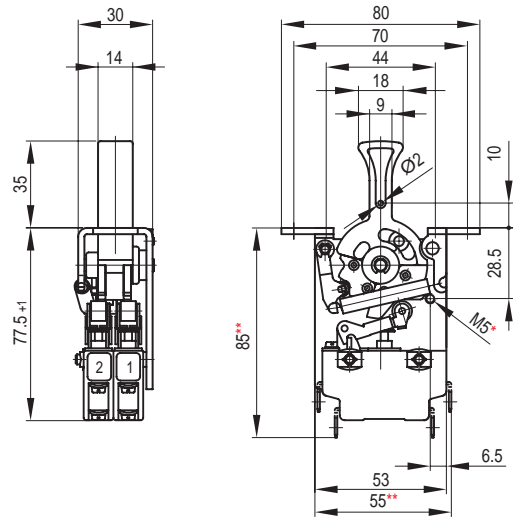
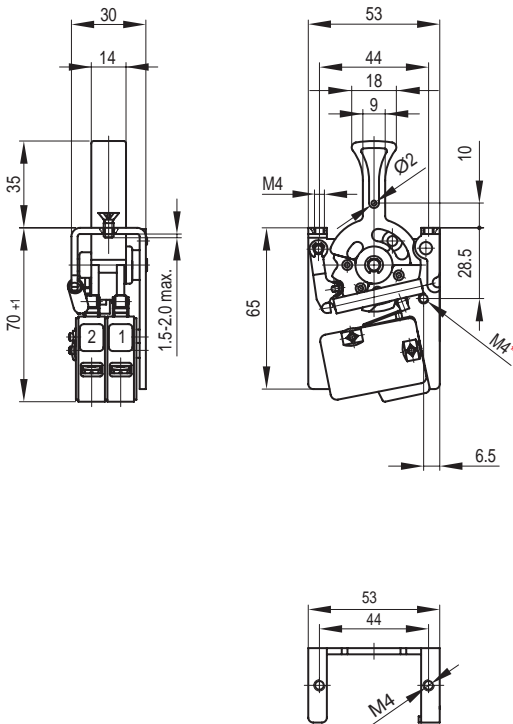

Special design FL for mounting with stud and thruhole Ø5.5 (see Ordering code, page 3).

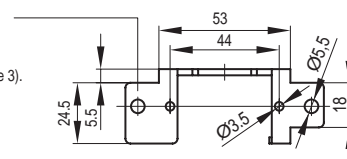

* Ground terminal
 ** Switching element with flat quick-connect terminals

Switch function

Series L, P

The switch function is a significant part of the ordering code. The table on the right shows stock items of 3- and 5-position contact assemblies of the L and P Series.

L Series

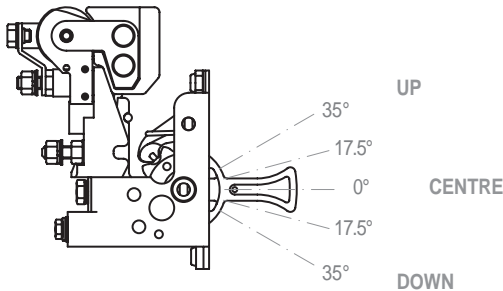

P Series

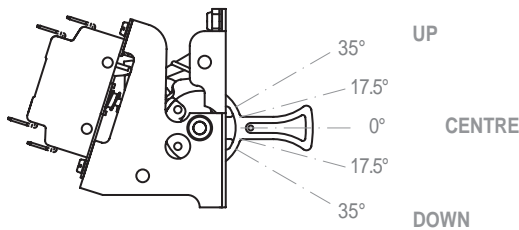

3-position contact assembly

Switch function code	Handle position		
	Down 35°	Centre 0°	Up 35°
S	maintained	0	maintained
2S	maintained	none	maintained
TS	momentary	0	maintained
ST	maintained	0	momentary
T	momentary	0	momentary

5-position contact assembly

Switch function code	Handle position				
	Down 35°	Down 17.5°	Centre 0°	Up 17.5°	Up 35°
S	maintained	maintained	0	maintained	maintained
V	maintained	momentary	0	momentary	maintained
VD	maintained	momentary	0	momentary	momentary
DV	momentary	momentary	0	momentary	maintained
T	momentary	momentary	0	momentary	momentary

Function:
0 Notched centre position or spring return with momentary contacts
none Notched position up/down 35° with 3-position assemblies
maintained Notched position
momentary Spring return to next position and neutral position resp.

Contact positions

Series L, P

Contact positions: All available contact positions of the respective switching element within the working range of the toggle switch assembly are delineated by an index number as shown below.

Configuration: Whenever two switching elements are used, they are arranged in order of ascending index numbers. This number sequence (separated by “/”) becomes an integral part of the ordering code. In assemblies with 3 and 4 switching elements the sequence is determined by the respective technical requirements, i.e. you order L-S 7/9/23/24, we deliver L-S 7/23/24/9.

Switch state: S800 / S826 Series snap-action switches and S005 / S007 / S008 Series switching elements have SPDT double-break contacts and a NC contact respectively.

The switch state symbols as shown in the tables below always refer to the state of the positively driven NC contact 1 – 2, see figure on the right.

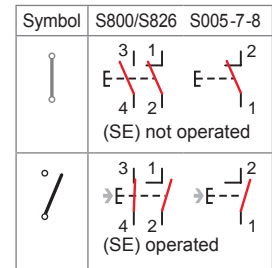

The state of the switching element (SE) is represented by the two symbols.

3-position contact assembly		Contact position												
Handle position	Up	35°	0	1	2	3	4	5	6	7	8	9	10	
	Handle position	Up	35°	no switching element mounted	1	2	blocked	3	4	5	6	7	8	9
17.5°			1		2	3	4	5	6	7	8	9	10	
Centre		0°	1		2	3	4	5	6	7	8	9	10	
Down	35°	1	2		3	4	5	6	7	8	9	10		
		17.5°	1		2	3	4	5	6	7	8	9	10	

5-position contact assembly		Contact position													
Handle position	Up	35°	0	5	8	11	12	13	14	5	8	11	12	13	14
	Handle position	Up	35°	no switching element mounted	5	8	11	12	13	14	blocked				
17.5°			5		8	11	12	13	14						
Centre		0°	5		8	11	12	13	14						
		17.5°	blocked						5	8	11	12	13	14	
Down	35°	5	8		11	12	13	14							
		17.5°	5		8	11	12	13	14						

5-position contact assembly (continued)		Contact position																															
Handle position	Up	35°	5	6	7	8	9	10	11	12	13	14	15	16	17	18	19	20	21	22	23	24	25	26	27	28	29	30	31	32	33	34	
		Up	17.5°	5	6	7	8	9	10	11	12	13	14	15	16	17	18	19	20	21	22	23	24	25	26	27	28	29	30	31	32	33	34
	Centre		0°	5	6	7	8	9	10	11	12	13	14	15	16	17	18	19	20	21	22	23	24	25	26	27	28	29	30	31	32	33	34
	Down	17.5°	5	6	7	8	9	10	11	12	13	14	15	16	17	18	19	20	21	22	23	24	25	26	27	28	29	30	31	32	33	34	
35°			5	6	7	8	9	10	11	12	13	14	15	16	17	18	19	20	21	22	23	24	25	26	27	28	29	30	31	32	33	34	

Switching elements

Series L, P

L Series toggle switch assemblies are equipped with S005 / S007 / S008 Series cam-operated switching elements which are especially suited for switching high loads up to 60 A.

In addition to that, S008 P5 and S008 P6 Series switching elements feature permanent-magnetic blowout for arc quenching.

P Series toggle switch assemblies are fitted with S800 or S826 Series snap-action switches which guarantee the fail-safe opening of the NC contact even if it has become welded in a short circuit situation.

S826 a/L Series switches feature additional permanent-magnetic blowout for arc quenching.

L Series switching elements				
Switching element	Code	Terminals	Contact position	Catalogue
S005 a	S5	Screw-type	3-position assembly 5-position assembly	D30.en
S007 c	S6			
S007 a	S7			
S008 P5	P5	Screw-type	3-position assembly 5-position assembly	D30.en
S008 P6	P6			

P Series switching elements				
Switching element	Code	Terminals	Contact position	Catalogue
S800 a	S800 a	Screw-type	3-position assembly 5-position assembly	D20.en
S800 a24	S800 a24	Quick-connect		
S800 a30	S800 a30	Screw with spring washer	3-position assembly 5-position assembly	D26.en
S826 a	S826 a	Screw-type		
S826 a24	S826 a24	Quick-connect		
S826 a/L	S826 a/L	Quick-connect		
S826 a10	S826 a10	Screw-type		
S826 a10/24	S826 a10/24	Quick-connect		

Switching element	S005 / S007 / S008 (L Series)	S800 / S826 (P Series)
Circuit diagram	1 — 2	3 — 4 1 — 2

Dimension diagrams

Series L, P

● **L Series** with S005 / S007 / S008 Series cam-operated switching elements

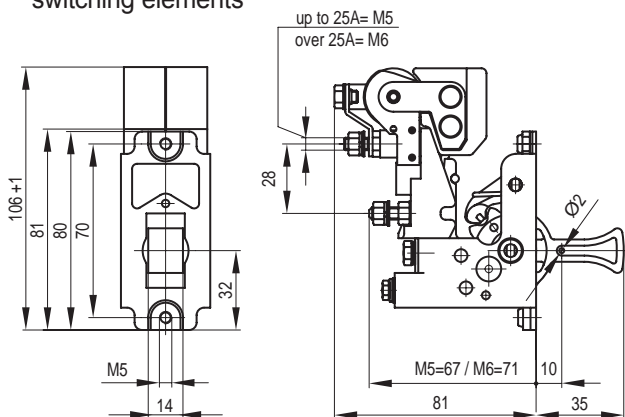

● **P Series** with S800 / S826 Series snap-action switches

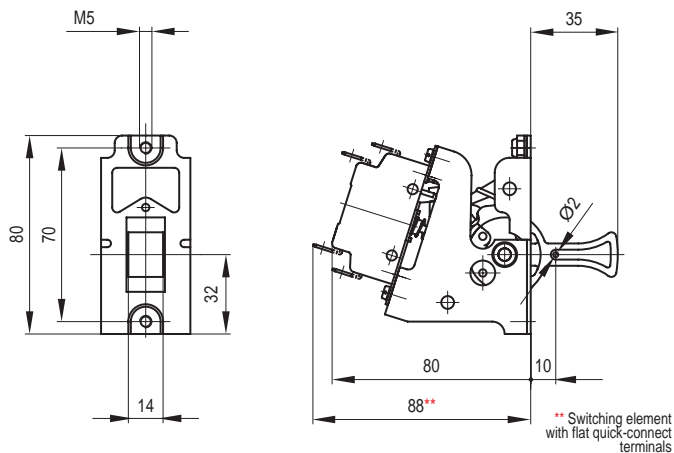

Terminal designation (shown on nameplate of toggle switch assembly)

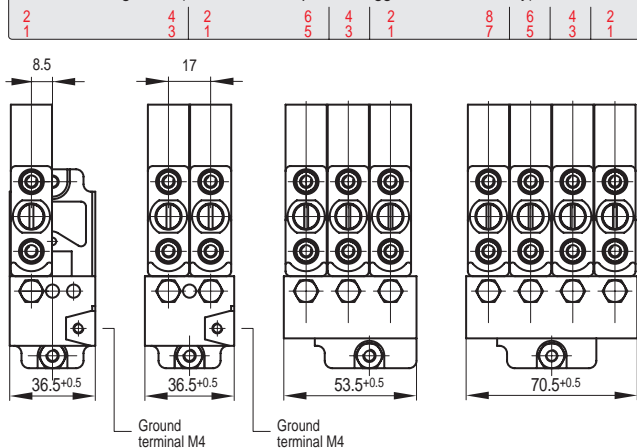

Sequential switch numbers (not shown on switching element itself)

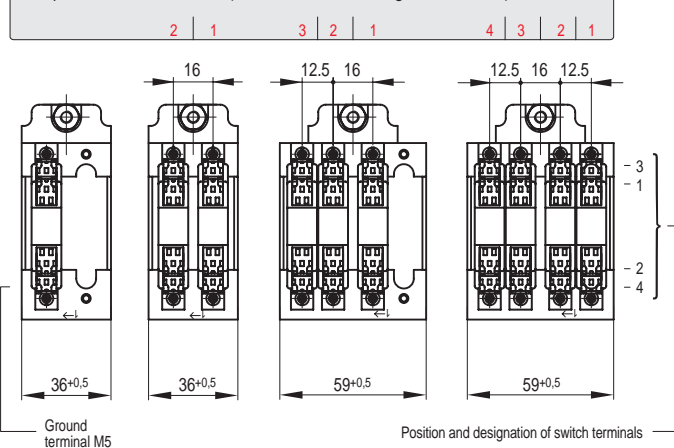

Special features and accessories

Series F, L, P

F Series

- Special features *1

FL	Toggle switch assembly for mounting with stud, thruhole \varnothing 5.5 mm*
V	Lock*
VL	Lock, extended*
SHK	Ball handle
SHG	T-handle

- Accessories *2

- Rubber ball \varnothing 30 for standard handle

L, P Series

- Special features *1

SO	Toggle switch assembly for mounting with stud, thruhole \varnothing 6.3 mm*
SE	Additional angle for earthing with hex screw M4
SHK	Ball handle
SHG	T-handle
SHL	Cylinder handle, long
SHM	Cylinder handle, short

- Accessories *2

- Countersink screw M5 with threaded bore M3 in the head of the screw
- Capstan head screw M3 for lead sealing
- Rubber ball \varnothing 30 for standard handle
- Switch identification plates without lettering
- Switch guard S608 (protection against accidental actuation)

*1 See ordering code on page 3
*2 To be ordered separately

Handle styles

Accessories Series F, L, P

- The special handle SH can be transformed into a ball handle, T-handle or cylinder handle
- A rubber ball \varnothing 30 mm can be mounted on the standard handle
- All handles feature a \varnothing 2 mm thruhole and can be lead-sealed
- Actuating force and mechanical endurance are influenced by style of handle

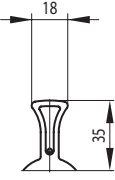
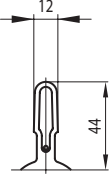
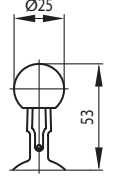
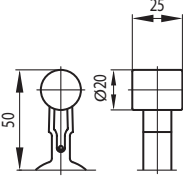
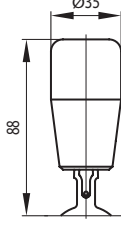
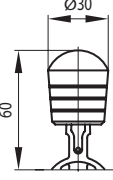
					
Standard handle	Special handle (SH)	Ball handle (SHK)	T-handle (SHG)	Cylinder handle (SHL)	Cylinder handle, short (SHM)



Nameplates

Accessories Series L, P

Nameplates are affixed with M3 screws fitting the threaded bore in the head of the M5 switch mounting screws. M5 countersink screws can be ordered as accessories from Schaltbau. The M3 nameplate screws, however, can not. They are not delivered with the nameplate.

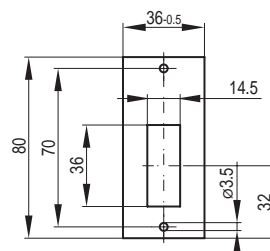
- Option A:** Material: Resopal. White background with black lettering, thickness 2 mm
- Option B:** Material: Resopal. Black background with white lettering, thickness 2 mm



Option	Background/lettering
A	
B	

Switch guard S608

Accessories Series L, P

As protection against accidental actuation of the toggle switch assembly the optional switch guard S608 is available.

Like the nameplate the switch guard S608 is affixed with M3 screws fitting the threaded bore in the head of the M5 switch mounting screws (Accessories). The switch guard can be mounted together with the nameplate. The M3 nameplate screws, however, are not delivered by Schaltbau.

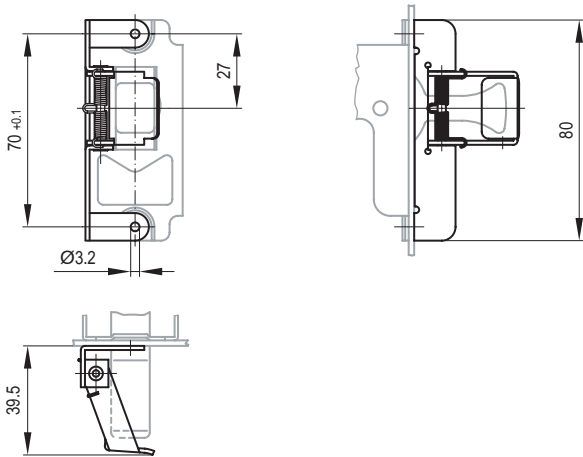

Cutouts, Clearance, Mounting

Series F, L, P

• Cutouts

The dimensions of the panel cutouts are only recommendations that allow for some tolerance. To make the cutouts look better we further recommend bevelling the edges.

F Series

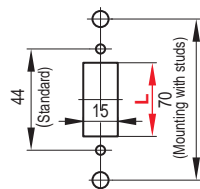

Panel thickness	L x 15 panel cut-out
2.0 ... 2.5 mm	32 x 15 mm
2.5 ... 4.0 mm	34 x 15 mm

L, P Series

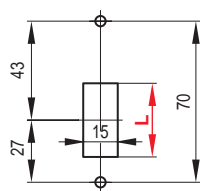

Panel thickness	L x 15 panel cut-out
2.0 ... 2.5 mm	30 x 15 mm
2.5 ... 3.5 mm	32 x 15 mm
3.5 ... 6.0 mm	35 x 15 mm

• Clearance towards live parts

With regard to L Series toggle switch assemblies observe the clearance towards live parts as shown below.

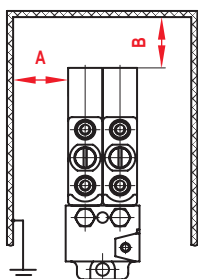

Dimension	Clearance	Switching element
A	2 mm	S005 S007 S008
B	10 mm	S005 S007
	30 mm	S008

• Mounting and in-line mounting

F Series: The toggle switch assembly is mounted by means of M4 countersink screws which are not included in the delivery. The FL version is designed for mounting with studs.

L, P Series: The toggle switch assemblies are mounted with M5 countersink screws which are included in the delivery. The special design SO is to be mounted with studs.

F Series:

L, P Series:

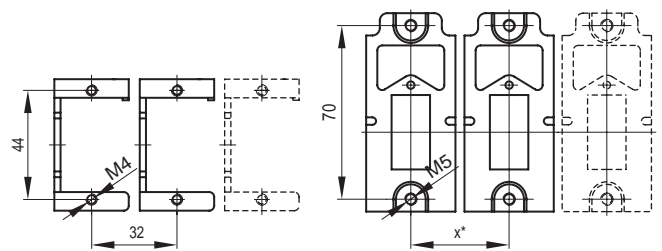

* x = 1/2 pole: 38 mm

3/4 pole: 61 mm

without earthing screw fastened to the side of the assembly

Timetable holder BFH

Series BFH

This device is designed for installation in driver's desks of locomotives and multiple units for holding timetables and other documents.

Clamping yokes can be unscrewed for use of short or long end (yoke turned at 180° compared with figure on the right).



Ordering code BFH

Series BFH

Example: **BFH-25-M5-L**

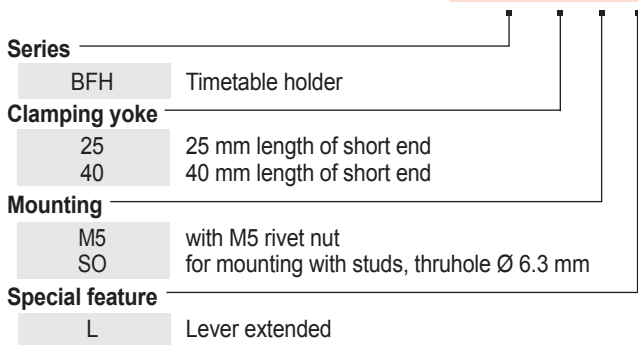

• Stock items

Ordering code	A* in [mm]	X* in [mm]
BFH-25-SO	25	18.75
BFH-25-M5-L	25	31.75
BFH-40-M5	40	18.75
BFH-40-SO	40	18.75

* see dimension diagram BFH Series

Dimension diagrams, Mounting

Series BFH

• Dimension diagrams

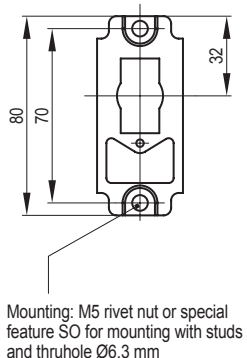
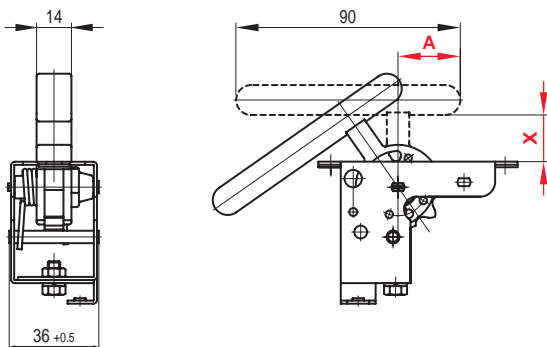

A in [mm]	Clamping yoke
25	25 mm length of short end of yoke
40	40 mm length of short end of yoke
X in [mm]	Special feature
18.75	Standard lever
31.75	Extended lever

Mounting: M5 rivet nut or special feature SO for mounting with studs and thruhole Ø6.3 mm

• Mounting

The required installation cutout is identical with the one for the L and P Series toggle switch assemblies, see also page 9 »Cutouts, Clearance, Mounting«.

Notes

A large area of the page is filled with horizontal dotted lines, providing a space for handwritten notes.



Schaltbau GmbH has an environment management system that has been certified since 1994.

Schaltbau GmbH has a quality management system that has been certified since 1994.

Electrical Components and Systems for Railway Engineering and Industrial Applications

Connectors

- Connectors manufactured to industry standards
- Connectors to suit the special requirements of communications engineering (MIL connectors)
- Charging connectors for battery-powered machines and systems
- Connectors for railway engineering, including UIC connectors
- Special connectors to suit customer requirements

Snap-action switches

- Snap-action switches with positive opening operation
- Snap-action switches with self-cleaning contacts
- Enabling switches
- Special switches to suit customer requirements

Contactors

- Single and multi-pole DC contactors
- High-voltage AC/DC contactors
- Contactors for battery powered vehicles and power supplies
- Contactors for railway applications
- Terminal bolts and fuse holders
- DC emergency stop switches
- Special contactors to suit customer requirements

Control devices

- Master controllers and reversers for railway applications
- Toggle switch devices
- Handles and foot switches for railway applications (dead-man equipment)
- Switching elements with high breaking capacity
- Emergency brake handles
- Signal devices

Transportation system equipment

- Power supplies for passenger coaches (electric equipment)
- Battery chargers for locomotives and passenger coaches
- High-voltage equipment for single and multi-phase operation
- Heating devices and heating controls
- Design and engineering services for high-voltage equipment
- Special equipment to suit customer requirements

Schaltbau GmbH

Hollerithstrasse 5
81829 Munich
Germany

Phone +49 89 9 30 05-0
Fax +49 89 9 30 05-350
e-Mail contact@schaltbau.de
Internet www.schaltbau.de

with compliments: