

# C300

1 pole bi-directional DC  
NO contactors up to 500 amps

---

## C300 - 1 pole bi-directional DC NO contactors

---

**Compact single-pole NO contactors for AC and DC up to 1,500 volts rated insulation voltage. Making current up to 4,500 amps; conventional thermal current up to 500 amps; short-time current up to 6,000 amps.**

The bi-directional DC contactors C300 switch high power in the smallest space. With a making capacity of up to 4,500 amperes, the extremely compact series is suitable for applications with high inrush currents or high capacitances. All versions can carry up to 500 amperes continuously. In the event of a short circuit, even

6,000 amperes may flow for 20 milliseconds without the contacts welding. This means that the contactor retains its full function to separate large powers when required: up to 500 amperes and up to 1,500 volts - regardless

of the direction of the current. This full bi-directionality is important for systems with a charging and discharging process, such as in battery storage or electric vehicles. Other typical applications are the DC circuit in inverters, combiner boxes in photovoltaic systems or the management of battery storage systems.

---

### Features

---

#### **Compact dimensions - high rated insulation voltage $U_i$ up to 1,500 volts**

Smallest dimensions - great performance! Nevertheless, all the air gaps in the contact area have been generously dimensioned. The rated insulation voltage is 1,500 volts.

The arc chamber of the C300 is made of plastic. This is efficient and saves weight.

#### **High thermal continuous current $I_{th}$ of up to 500 amps**

All versions of the C300 can permanently carry up to 500 amps - provided a sufficiently dimensioned connection cross-section of 300 mm<sup>2</sup>. The maximum ambient temperature for industrial applications is 85 °C. These excellent values are achieved through very high contact forces.

#### **High making capacity $I_{cm}$ of up to 4,500 amps**

The C300 can switch on a current of up to 4,500 amps.

High contact forces and burn-off resistant silver contacts favour the excellent breaking capacity.

An integrated PWM controller regulates the coil current for all operating states, ensures low-bounce switching on and optimises the holding power.

#### **High short-time withstand current rating $I_{cw}$ of up to 6,000 amps**

For 20 milliseconds, the C300 can carry a current of up to 6,000 amps without the contacts welding. This time is sufficient for the short-circuit protection to trip. The short-time current carrying capacity is supported by high contact forces and an optimised contact geometry.

#### **Full bi-directionality - reliable disconnection of high performances**

All versions of the C300 can reliably separate high currents and voltages when required, regardless of the direction of the current. These properties are achieved by the special arrangement of blowout magnets and arc chamber, burn-off resistant silver contacts, high contact forces and generously dimensioned air gaps in the contact area.

#### **Auxiliary switch with mirror contact function**

The C300 contactors have an integrated auxiliary contact with mirror contact function according to IEC 60947-4-1, annex F. Mirror contacts are required in feedback circuits of safety controls. The mirror contact function informs about the switching state and ensures that the NC contact of the auxiliary contact is not closed at the same time as the NO main contact.

---

### Standards

---

#### **IEC 60947-4-1**

Low-voltage switchgear and controlgear - Part 4-1: Contactors and motor starters - Electromechanical contactors and motor starters

#### **UL 60947-4-1**

Low-Voltage Switchgear and Controlgear - Part 4-1: Contactors and Motor-Starters - Electromechanical Contactors and Motor-Starters.

#### **GB/T 14048.4**

Low-Voltage Switchgear and Controlgear - Part 4-1: Contactors and Motor-Starters - Electromechanical Contactors and Motor-Starters.

## Reliable, robust and economical

Contactors of the C300 series are designed for continuous currents of 500 amps. The switchgear has both high making and breaking capacities, and a high short-time withstand current. This ensures high operational safety.

An integrated electronic coil control ensures a constant and reliable switching behaviour independent of the ambient temperature. In addition, the energy consumption and associated heat development of the monostable design is noticeably reduced when switched on.

Dependent on the application, high requirements can be placed on electromechanical components. The new DC contactors are highly resistant to shock and vibration loads and meet the high requirements of ISO 16750.

## Ordering key

### C300-500-G0P-24I-V1

Series, configuration

**C300** 1 pole DC NO contactor,  
Rated operational voltage 1,000 V DC

Conv. thermal current

**500**  $I_{th} = 500$  A

Assembly

**G** Mounting holes  
**R** Top-hat rail mounting

Terminal main contacts

**0** Hole  $\varnothing 8.75$  mm, fixed contacts solid copper  
**1** Thread M6, fixed contacts solid copper

Connector coil and aux. switch

**P** Phoenix Contact MCV 1.5/4-GF-3.5

Auxiliary switches, configuration

1x Integrated aux. contact NC **V1**  
with mirror contact function to  
IEC 60947-4-1, annex F

Coil design

Monostable with PWM module **I**

Coil voltage

$U_s = 12 \dots 24$  V DC **24**

### Accessories

Connector for connecting coil and auxiliary switch  
4-pole PCB connector FMC 1,5/4-STF-3,5  
Phoenix Part-No. 1966114, can be ordered separately

**Note:** Presented in this catalogue are only stock items which can be supplied in short delivery time. For some variants minimum quantities apply. Please do not hesitate to ask for the conditions.

**Special variants:** If you need a special variant of the contactor, please do not hesitate to contact us. Maybe the type of contactor you are looking for is among our many special designs. If not, we can also supply customized designs. In this case, however, minimum order quantities apply.

## Applications

Due to many years of experience and expertise in the development of electromechanical switchgear and the control of DC arcs Schaltbau has developed an innovative solution with

The compact switching device can be integrated especially in areas where there is no space for larger series. Since the C300 series can reliably switch in both directions of current, it is ideally suited for applications with energy recovery. Here, the C300 reliably ensures the galvanic isolation of both poles of the battery from the vehicle's powertrain in the event of a fault. Are-

### Applications for e-mobility

- DC fast charging stations
- Battery test benches for the automotive industry
- Battery management for zero-emission propulsion systems in maritime applications and DC charging on and off-shore





the new compact contactors that further simplify applications in DC switching technology.

as of application for the C300 series are regenerative systems and DC charging stations or battery test benches. A further application for the use of bi-directional contactors of the C300 series are stationary energy storages. Batteries are charged and discharged regularly. For this purpose it is important that the contactors can switch off safely in both current directions.

### Stationary applications

- Grid stabilization and battery energy storage
- Regenerative systems in industrial plants
- Battery management systems
- Photovoltaics and UPS

## Specifications

<b>Series</b>		<b>C300</b>
Type of voltage		DC, bi-directional
Main contacts, configuration		1x, NO
<b>Electrical data according to IEC/UL 60947-4-1, GB/T 14048.4</b>		
Rated operational voltage $U_e$ max.		1,000 V (1,500 V for occasional switching)
Rated insulation voltage $U_i$		1,000 V @ PD3 / 1,500 V @ PD2
Rated impulse withstand voltage $U_{imp}$		10 kV
Pollution degree / Overvoltage category		PD2, PD3: see $U_e$ and $U_i$ / OV3
Conventional free air thermal current $I_{th}^{*1}$	IEC 60947-4-1 @ $T_a = 70^\circ\text{C}$ (cross section) UL 60947-4-1 @ $T_a = 40^\circ\text{C}$ (cross section) UL 60947-4-1 @ $T_a = 70^\circ\text{C}$ (cross section)	500 A (300 mm <sup>2</sup> ) 500 A (300 mm <sup>2</sup> ) 400 A (300 mm <sup>2</sup> )
Power dissipation per pole $I_{th}$	@ $70^\circ\text{C}$ , typical	31 W
Pole impedance	typical	130 $\mu\Omega$
Utilization category DC-1*2, $U_e = 1,000\text{ V}$		
Rated operational current $I_e$	IEC/UL 60947-4-1	10 A
Frequency of operation (operations per hour) $I_e$	DC-1	360 h <sup>-1</sup>
Rated short-time withstand current $I_{cw}$ , $L < 50\ \mu\text{H}$	@ $t = 20\text{ ms}$ , typical @ $t < 20\text{ ms}$ , typical	6,000 A < 25,000 A (contact welding - no explosion, no fire)
Rated short-circuit making capacity $I_{cm}$	$L < 50\ \mu\text{H}$	4,500 A
Breaking capacity	$L < 50\ \mu\text{H}$ , other values on request	
Single contact	$U_e = 230\text{ V} / I_e = 3,000\text{ A}$ $U_e = 400\text{ V} / I_e = 1,800\text{ A}$ $U_e = 800\text{ V} / I_e = 350\text{ A}$	5 operations 5 operations 5 operations
Double contact circuit	$U_e = 460\text{ V} / I_e = 3,000\text{ A}$ $U_e = 800\text{ V} / I_e = 1,800\text{ A}$ $U_e = 1,500\text{ V} / I_e = 350\text{ A}$	5 operations 5 operations 5 operations
UL special use ratings	$L < 250\ \mu\text{H}$ , other values on request	
Single contact	$U_e = 400\text{ V} / I_e = 200\text{ A}$ $U_e = 400\text{ V} / I_e = 1,200\text{ A}$ $U_e = 450\text{ V} / I_e = 900\text{ A}$ $U_e = 800\text{ V} / I_e = 250\text{ A}$	50 operations 5 operations 5 operations 5 operations
Double contact circuit	$U_e = 450\text{ V} / I_e = 3,000\text{ A}$ $U_e = 850\text{ V} / I_e = 1,000\text{ A}$ $U_e = 850\text{ V} / I_e = 500\text{ A}$	5 operations 5 operations 50 operations
<b>Main contacts</b>		
Contact material		AgSnO <sub>2</sub>
Terminals		Hole $\varnothing$ 8.75 mm (for M8) or thread M6x1
Torque		Hole: 10 ... 12 Nm / Thread: 8 ... 10 Nm for screws with property class 8.8
<b>Auxiliary contacts</b>		
Number, configuration		1 NC
Mirror contact function	IEC 60947-4-1, annex F	●
Rated operational voltage $U_e$	min. / max.	9 V / 24 V
Conventional free air thermal current $I_{th}$	min. / max.	10 mA / 1.5 A (4.5 A @ 50 ms)
Terminals		Connector, see ordering key
<b>Magnetic drive (monostable)</b>		
Coil voltage $U_s$ (Operating range) *3		12 ... 24 V DC (10.5 ... 36 V DC)
Pollution degree / Overvoltage category		PD2 / OV2
Coil power dissipation, max. ( $T_a = 20^\circ\text{C} / U_s$ )	Pull-In power (0.2 s) Holding power	50 W @ 24 V 3.5 W
Frequency of operation (operations per hour, no load)	$T_a = 20^\circ\text{C} / 85^\circ\text{C}$	1,800 h <sup>-1</sup> / 900 h <sup>-1</sup>
Pull-in time ( $T_a = 20^\circ\text{C} / U_s$ ) / Drop-off time ( $T_a = 20^\circ\text{C} / U_s$ )	typical	33 ms / 5 ms
Coil suppression		Integrated
Coil terminal		Connector, see ordering key
<b>Mounting position</b>		
		vertical / horizontal
<b>Degree of protection</b>	IEC 60529	IP00
<b>Mechanical endurance</b>		200,000 operations
<b>Shock / Vibration</b>	IEC 61373	Category 1, Class B
<b>Environmental conditions</b>	Operating temperature / Storage temperature Altitude / Humidity (EN 50125-1)	-40° C ... +70° C (short-term up to +85° C) / -40° C ... +85° C < 2,000 m above sea level / < 75 % on an annual average
<b>Approvals</b>		   
<b>Weight</b>		< 0.75 kg

\*1 In the application, the terminal temperature must not exceed 130° C permanently.

\*2 Corresponds to 50 switching operations 1.5 x  $I_e$  and 6,000 switching operations 1.0 x  $I_e$

\*3 For a safe pull-in, the voltage must reach the lower value of the coil voltage  $U_s$  function range within a maximum of 1 ms.

**C300-500-G1P-xxl-V1: Version with PWM module, for screw mounting**

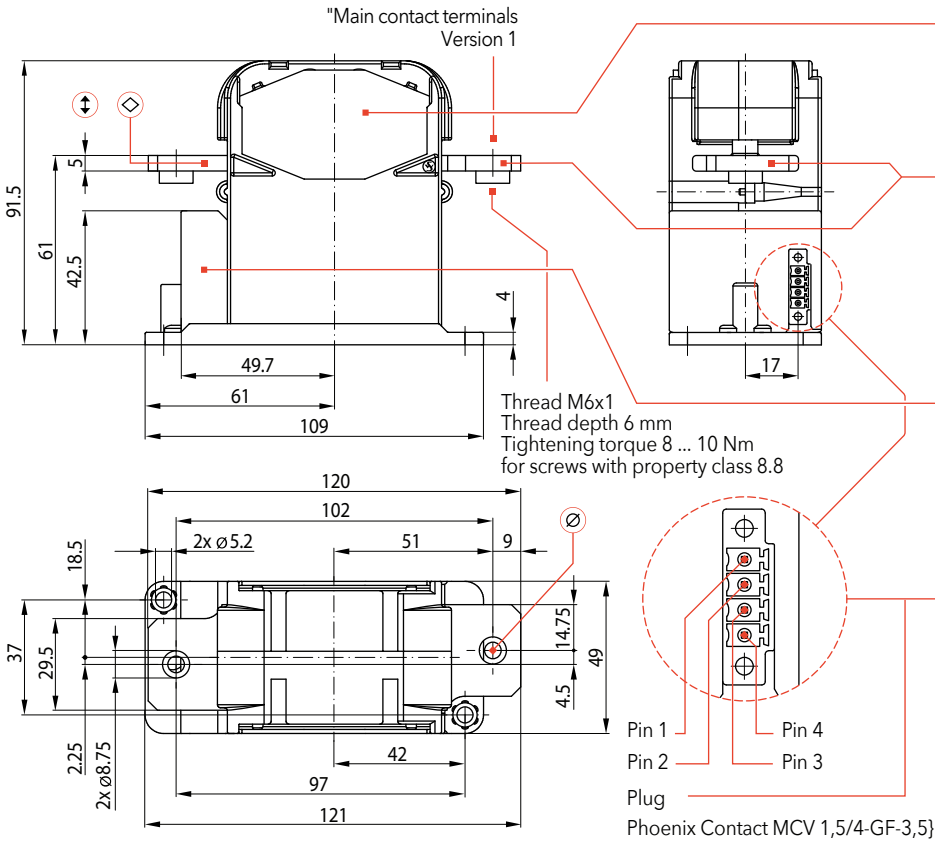

**Arc chamber main contact system**

- Massive designed 1-pole contact system
- Highly efficient plastic arc chamber with permanent magnetic blowing

**Main contact terminals**

- ◇ Material: Copper
- ⊕ Thickness: 5 mm
- ⊙ Version 0: Hole Ø 8.75 mm
- Version 1: Thread M6x1

**Electronic coil controller**

Permanently reliable switching behaviour regardless of ambient temperature, reduced energy consumption and less heat generation.

**Connection coil/auxiliary switch**

- Pin 1: Coil, terminal 1: +Us
- Pin 2: Coil, terminal 2: -Us
- Pin 3: NC contact, terminal 1
- Pin 4: NC contact, terminal 2

**i** A connector FMC 1,5/4-STF-3,5 (Phoenix Part-No. 1966114) is required to connect the coil and the auxiliary switch.

**C300-500-R0P-xxl-V1: Version with PWM module, for top-hat rail mounting**

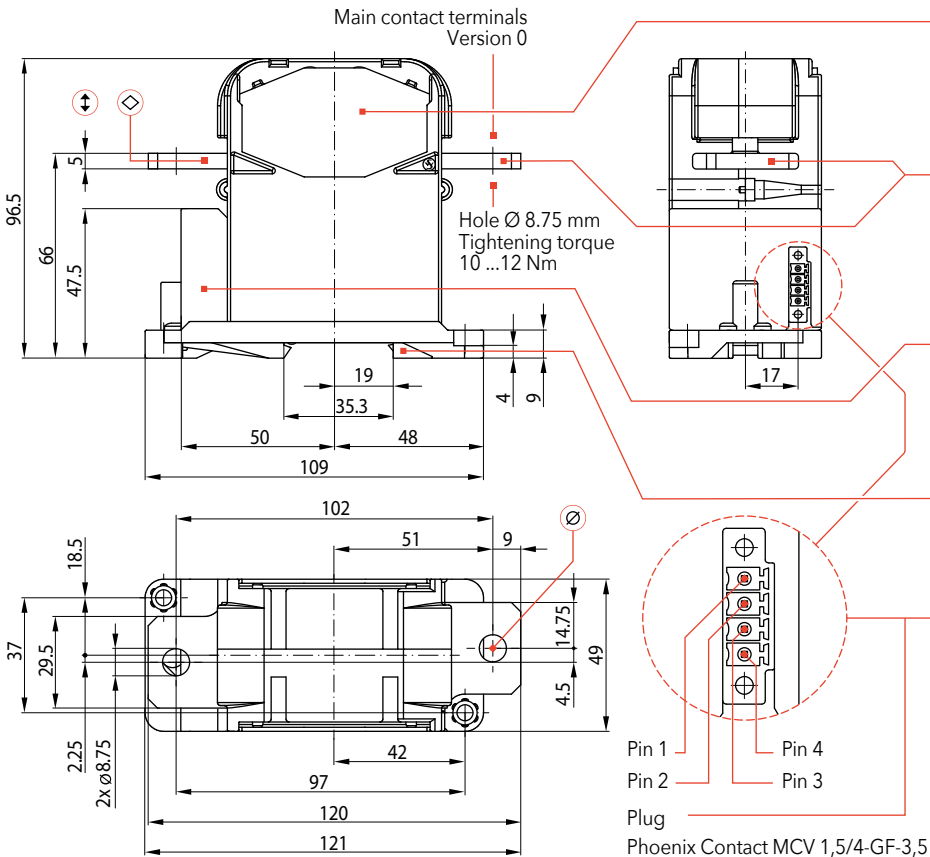

**Arc chamber main contact system**

- Massive designed 1-pole contact system
- Highly efficient plastic arc chamber with permanent magnetic blowing

**Main contact terminals**

- ◇ Material: Copper
- ⊕ Thickness: 5 mm
- ⊙ Version 0: Hole Ø 8.75 mm
- Version 1: Thread M6x1

**Electronic coil controller**

Permanently reliable switching behaviour regardless of ambient temperature, reduced energy consumption and less heat generation.

**Top-hat rail mounting**

Mounting on mounting rail NS 35/15 according to IEC 60715

**Connection coil/auxiliary switch**

- Pin 1: Coil, terminal 1: +Us
- Pin 2: Coil, terminal 2: -Us
- Pin 3: NC contact, terminal 1
- Pin 4: NC contact, terminal 2

**i** A connector FMC 1,5/4-STF-3,5 (Phoenix Part-No. 1966114) is required to connect the coil and the auxiliary switch.

## Electrical endurance

### Predicted electrical endurance as a function of the breaking current, 1x C300

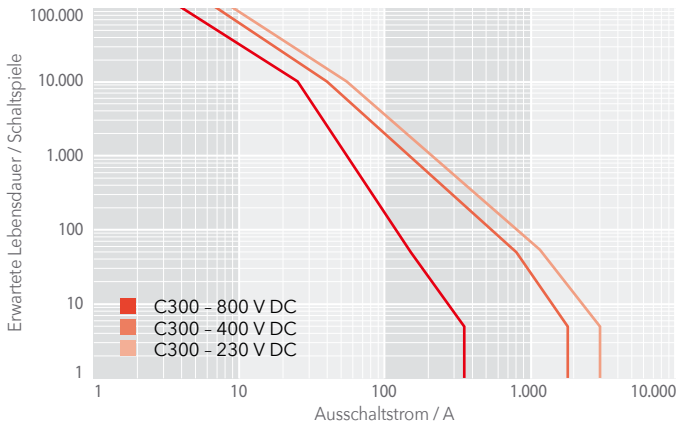

### Predicted electrical endurance as a function of the breaking current, series connection 2x C300

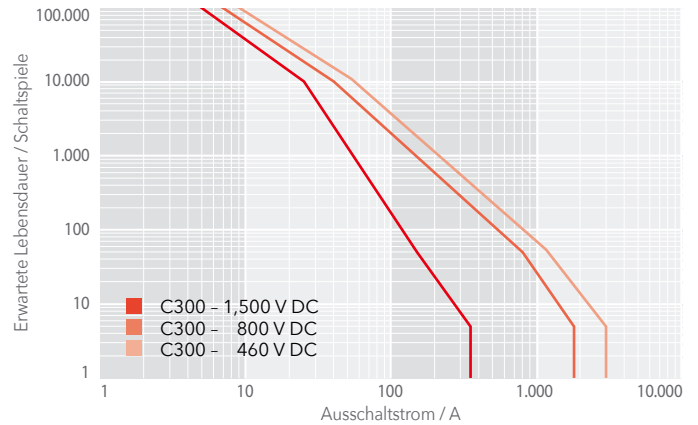

## Circuit diagram, connection

### Circuit diagram, version with PWM module

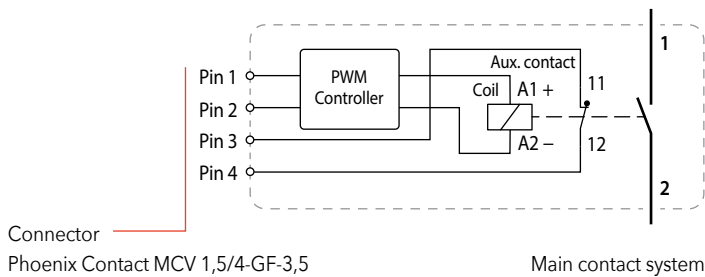

### 4-pole connector for connecting of coil and auxiliary switch

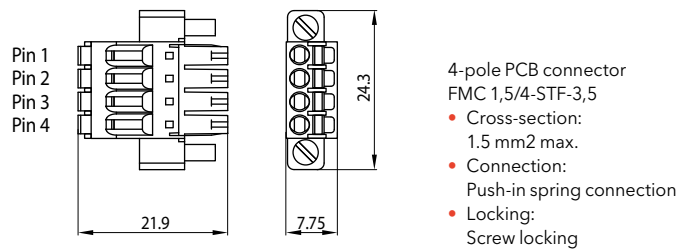

#### Contact assignment

Terminal	Contact	Description
Main contacts	1	Hauptkontakt 1 Fixed contact, solid copper
	2	Hauptkontakt 2 Fixed contact, solid copper
Coil contacts	Pin 1	Coil A1+ U <sub>s</sub> + Connector Phoenix Contact
	Pin 2	Coil A2+ U <sub>s</sub> - Phoenix Contact MCV 1,5/4-GF-3,5
Aux contacts	Pin 3	Contact 11
	Pin 4	Contact 12

#### Contact assignment

Terminal	Contact	Description
Coil contacts	Pin 1	Coil A1+ U <sub>s</sub> + Connector Phoenix Contact
	Pin 2	Coil A2+ U <sub>s</sub> - Phoenix Contact MCV 1,5/4-GF-3,5
Aux contacts	Pin 3	Contact 11
	Pin 4	Contact 12

## Minimum distances, mounting holes

### Minimum distances

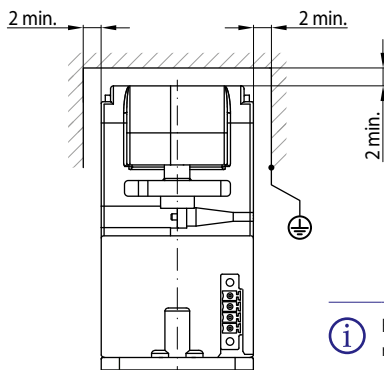

**i** For the C300 series there is a minimum distance of 2 mm to magnetically active, live or earthed parts.

### Mounting holes

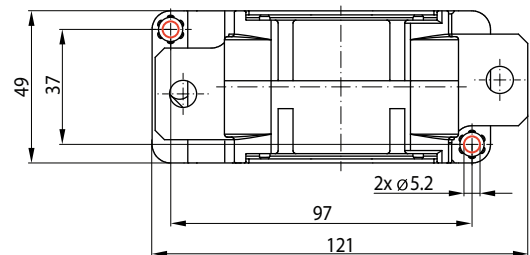

**i** The contactors with mounting type "G" are mounted on a suitable mounting plate with two M5 screws. Tightening torque: 5 ... 6 Nm for screws with property class 8.8

## Permissible mounting orientations

### C300-500-G0P-xxl-V1: Screw mounting version

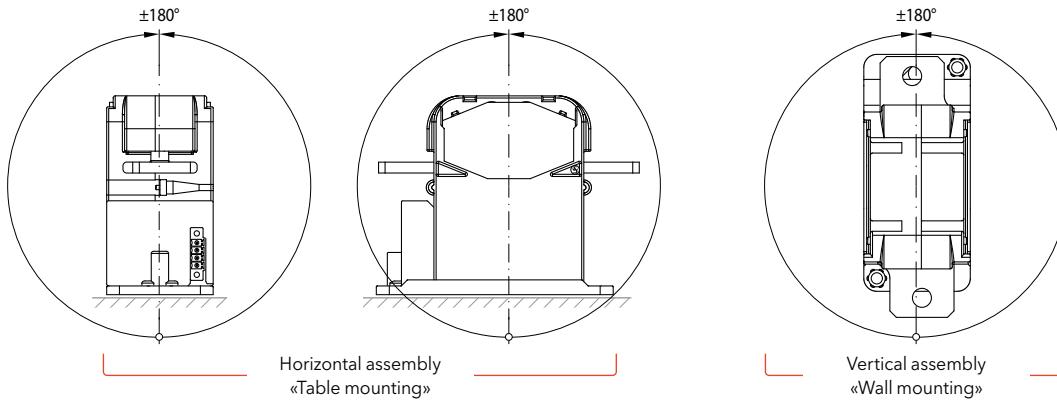

### C300-500-R0P-xxl-V1: Version for top-hat rail mounting

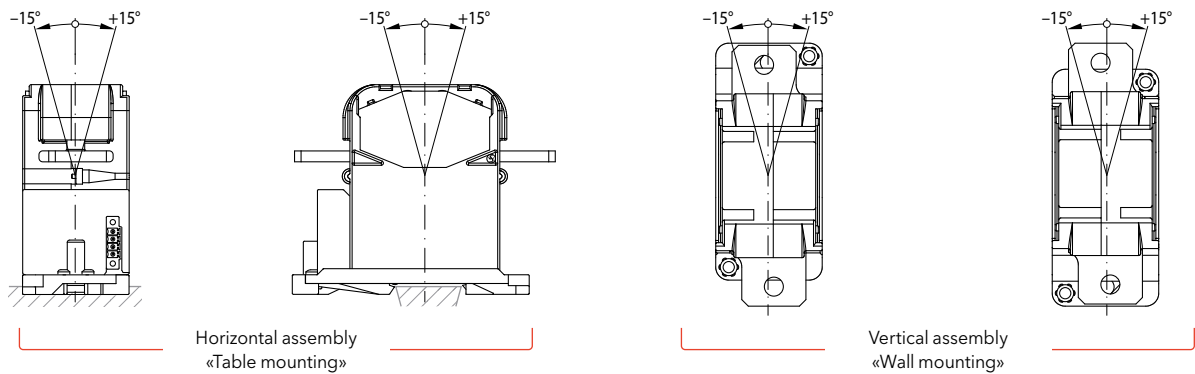

## Maintenance and safety instructions

### Maintenance:

- C300 series contactors are basically maintenance free.
- Make regular in-depth visual inspections once or twice a year.

### Safety instructions:

- The device must be used according to the intended purpose as specified in the technical documentation. You are obliged to observe all specifications depending on operating temperature, degree of pollution etc. that are relevant to your application.
- Without further safety measures the contactors are not suited for use in potentially explosive atmospheres.
- In case of malfunction of the device or uncertainties stop using it any longer and contact the manufacturer instantly.
- Tampering with the device can seriously affect the safety of people and equipment. This is not permitted and leads to an exclusion of liability and warranty.
- Coil suppression for reducing surges when the coil is switched off is optimally attuned to the contactors switching behaviour. The existing opening characteristic must not be negatively influenced by parallel connection with an external diode.
- Contactors running permanently may heat up. So make sure that the contactor has sufficiently cooled down before you start any inspection or maintenance work.



For detailed maintenance, safety and mounting instructions please refer to our operating manuals > [C300-M.en!](#)



Defective contactors or parts (e.g. arc chambers, auxiliary switches) must be replaced immediately!



For a detailed list of all safety instructions see here: > [schaltbau.info/safety3en!](#)

## We enable electrification for a sustainable future

Schaltbau is a global technology leader specializing in contactors, connectors, switches, and electrical devices.

As pioneers of electrification, Schaltbau has been championing safety on rail for generations. Building on nearly a century of rail experience, with our brand Eddicy we also create future-oriented products and solutions with the highest standards of safety and reliability to switch, connect, control and protect DC applications in energy and e-mobility.

Headquartered in Germany, Schaltbau has a worldwide presence with 12 production and sales sites on all major continents.

Find out more on [www.schaltbau.com](http://www.schaltbau.com).